

Swap body bolster rigid 160 x 85

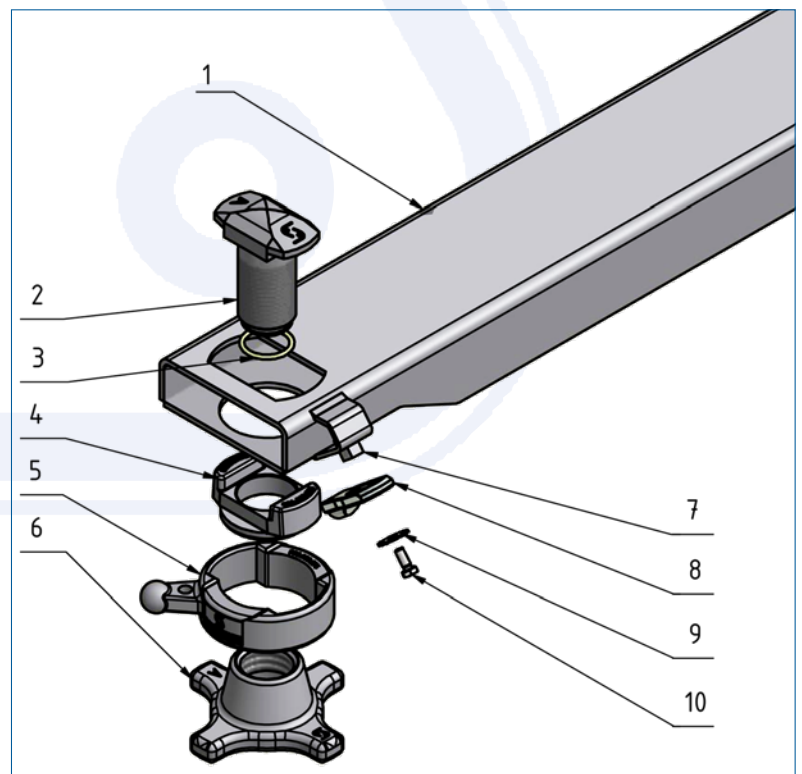

- > steel raw
- > integrated twist locks (galvanised *inner parts 410.075.620*)
- > 1 twist lock on each side
- > bolster 80 mm high
- > weight 70 kg

Art.-No. 410.076.400

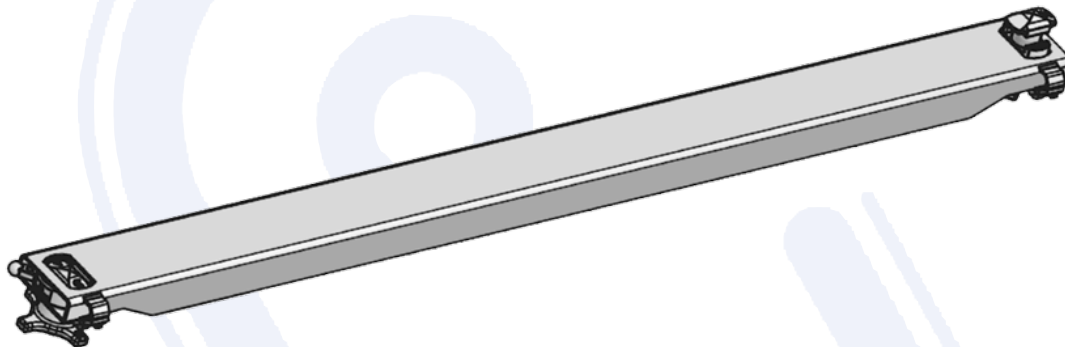
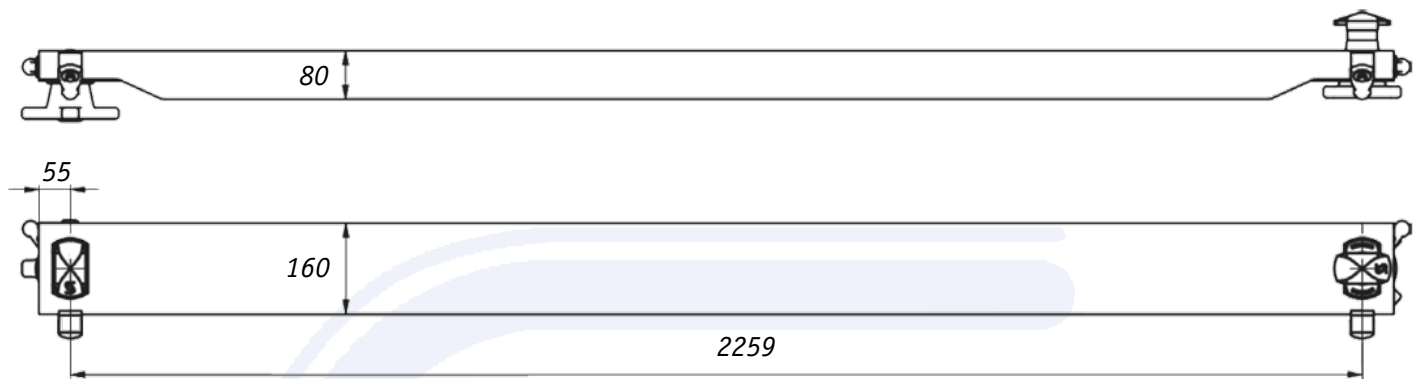

Pos.	Single part	Art.-No.
1	Bolster	410.076.112
2	Locking pin	906.000.276
3	Security ring	905.000.187
4	Locking pin guide	906.000.273
5	Outer guide	906.000.274
6	Locking nut	906.000.275
7	Holder for security latch	905.159.006
8	Security latch	905.159.005
9	Washer	905.036.005
10	Screw	020.008.016