

# Twist lock fully retractable

- > for platform chassis in acc. with ISO-norm
- > **with 38 mm locking pin and security ring**
- > steel housing raw for welding on, all inner parts are galvanized and not installed
- > 200 x 230 x 170 mm
- > limited suitability for hot-dip galvanising
- > weight 13 kg

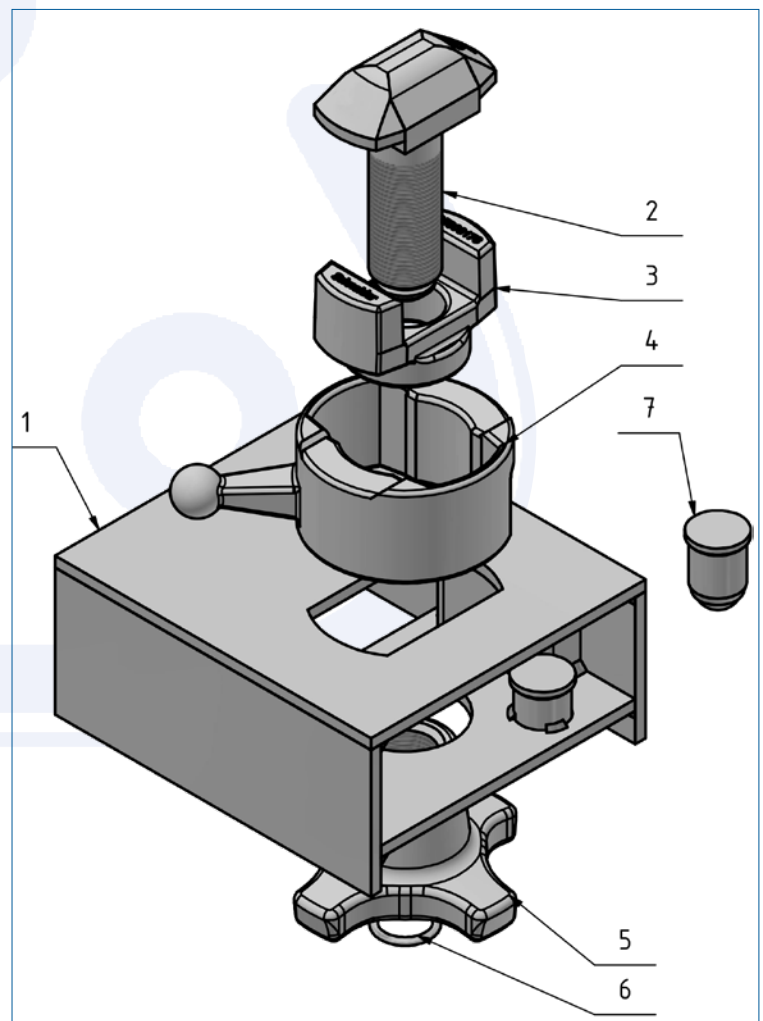

Art.-No. 905.202.200

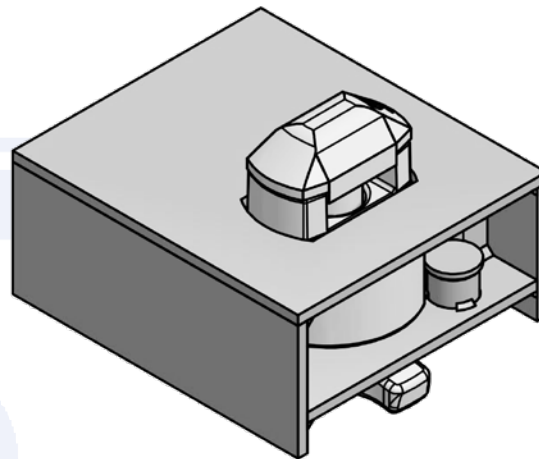
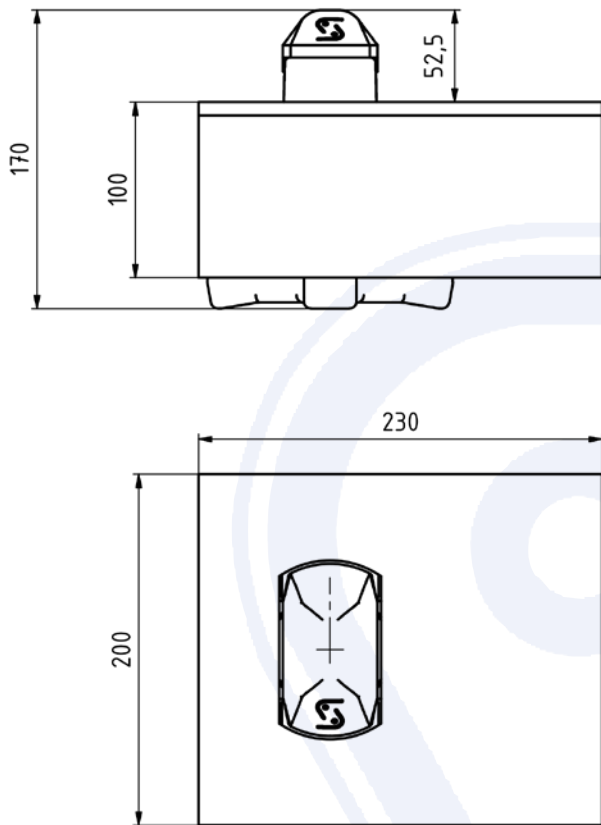

Pos.	Single part	Art.-No.
1	Housing	906.202.200
2	Locking pin	905.000.137
3	Locking pin guide	905.000.178
4	Outer guide	905.000.177
5	Locking nut	905.000.127
6	Security ring	905.000.190
7	Security ball	905.000.143