

# Twist lock fully retractable

- > for platform chassis in acc. with ISO-norm
- > for swap systems in acc. with ISO-norm
- > **with 52 mm locking pin and security ring**
- > steel housing raw for welding on, all inner parts are galvanized and not installed
- > 245 x 200 x 100 mm
- > weight 13 kg

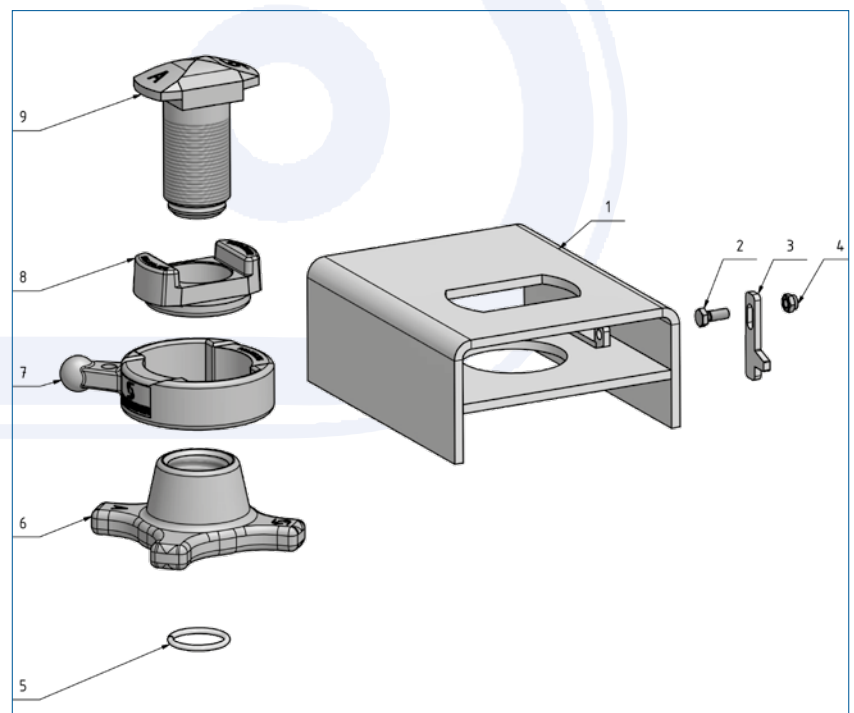

**Art.-No. 905.202.350**

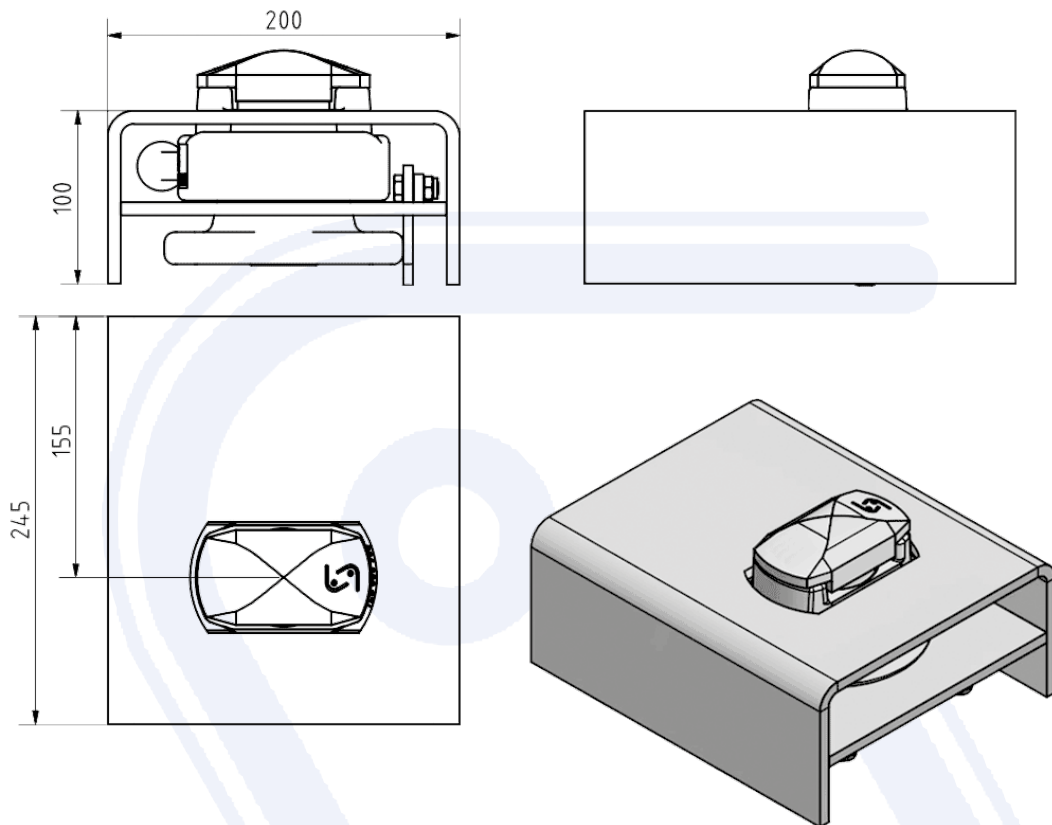

Pos.	Single part	Art.-No.
1	Housing	906.202.350
2	Screw M8x20	650.013.009
3	Security latch	411.670.003
4	Self-locking nut M8	640.008.008
5	Security ring	905.000.187
6	Locking nut	906.000.275
7	Outer guide	906.000.274
8	Locking pin guide	906.000.273
9	Locking pin	906.000.276