

Twist lock fully retractable

- > for swap systems right hand side
- > **with 52 mm locking pin and security ring**
- > steel housing raw for welding on, all inner parts are galvanized and not installed
- > 180 x 185 x 160 mm
- > **with back plate** 120 mm
- > weight 11 kg

Art.-No. 905.237.502

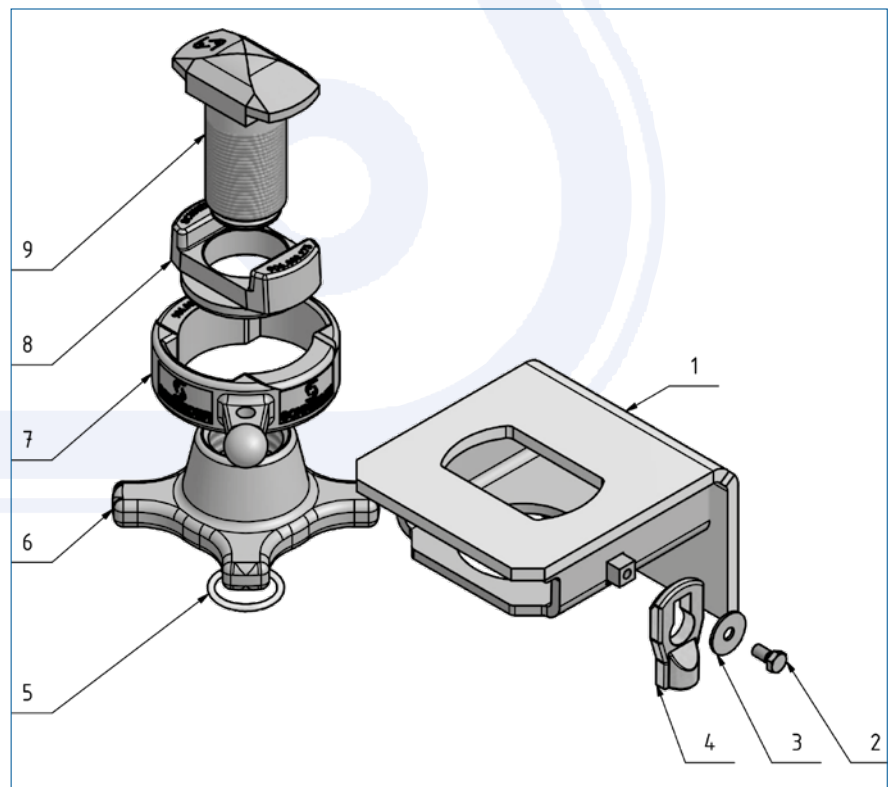
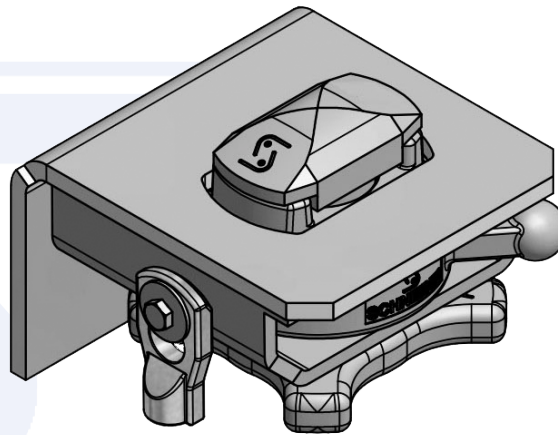
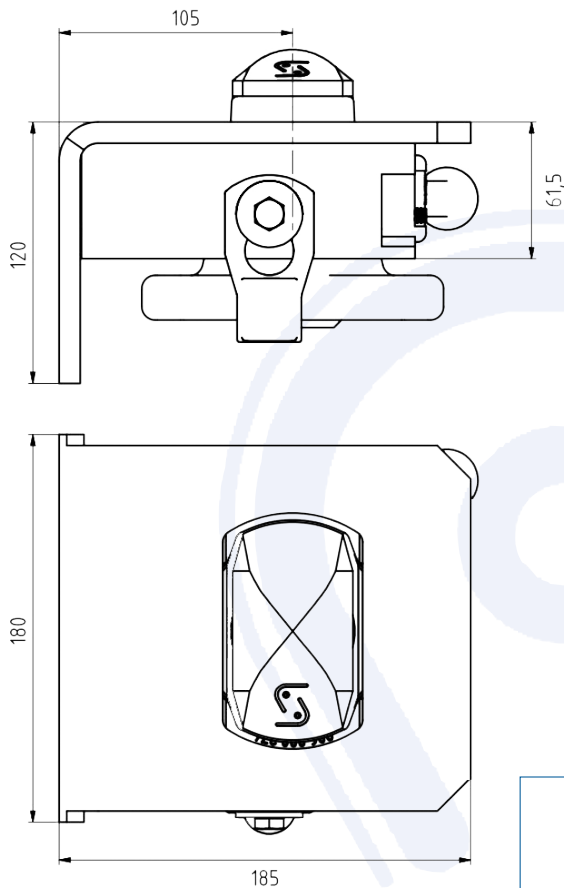

Pos.	Single part	Art.-No.
1	Housing right	906.274.012
2	Screw M8x16	020.008.016
3	Safety washer	905.036.005
4	Security latch	905.159.005
5	Security ring	905.000.187
6	Locking nut	906.000.275
7	Outer guide	906.000.274
8	Locking pin guide	906.000.273
9	Locking pin	906.000.276