

# Twist Lock adjustable

- > for container chassis
- > 52 mm locking pin and ring
- > radial movable from 2.259 to 2.286 mm („Sealand“)
- > cast finish, inner parts removable
- > all inner parts are galvanized and not installed
- > weight 14 kg

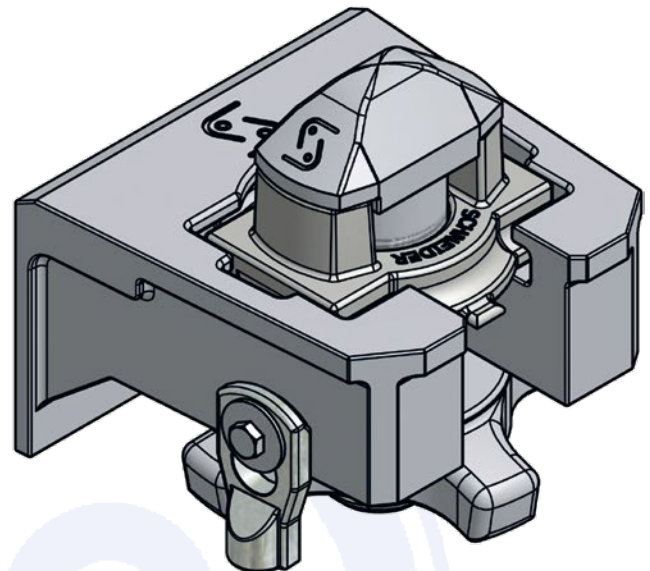

Art.-No. 905.165.000

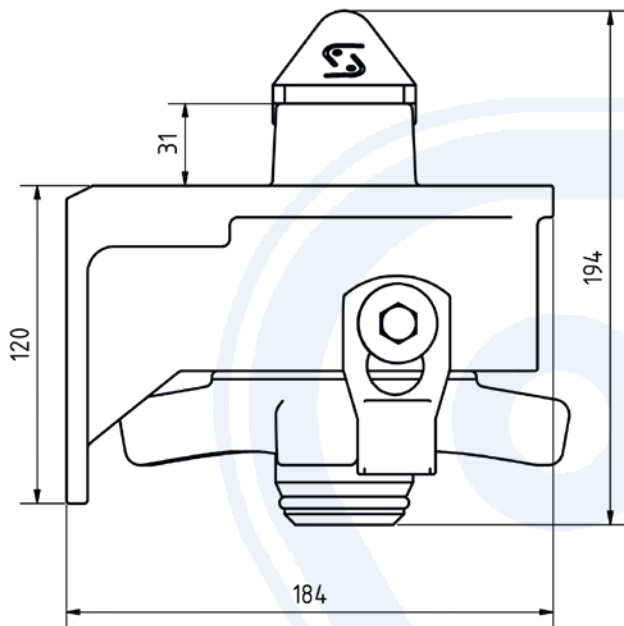

Pos.	Spare part	Art.-No.
1	Inner part	905.000.217
2	Housing kpl.	905.300.216
3	Locking pin	905.000.213
4	Locking nut	905.000.088
5	Security ring	905.000.187
6	Security latch	905.159.005
7	Washer	905.036.005
8	Screw	020.008.016

