

Twist Lock displaceable

- > housing steel hot-dip galvanised
- > for container chassis, with intermediate layer
- > 52 mm locking pin and ring
- > radial movable from 2,259 mm to 2,286 mm („Sealand“)
- > all inner (cast) parts are galvanized and not installed
- > weight 23 kg

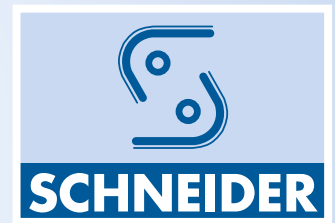

Art.-No. 905.167.000

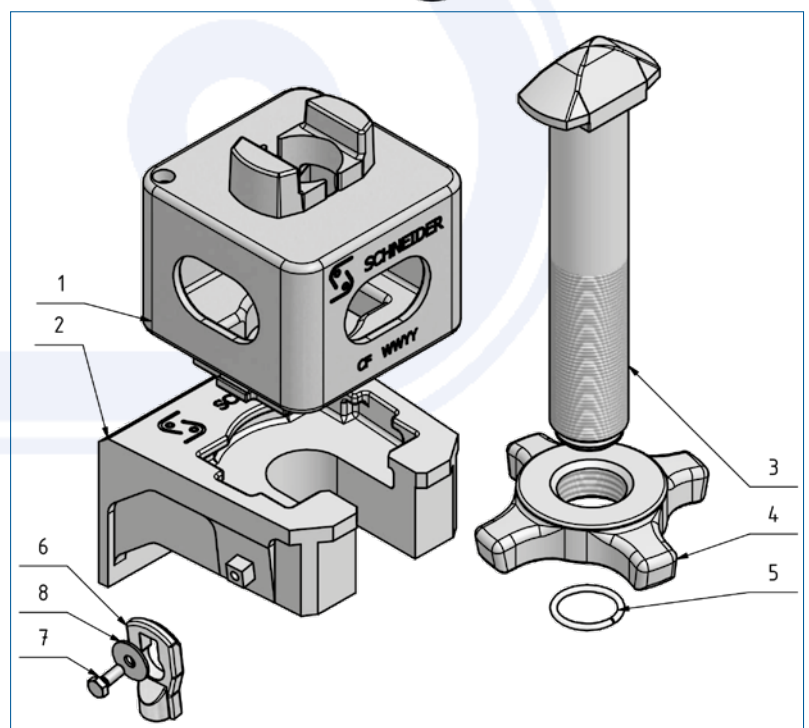
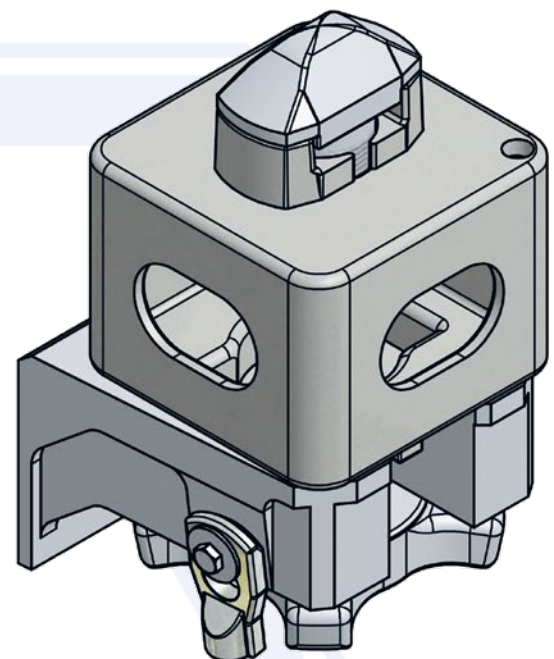
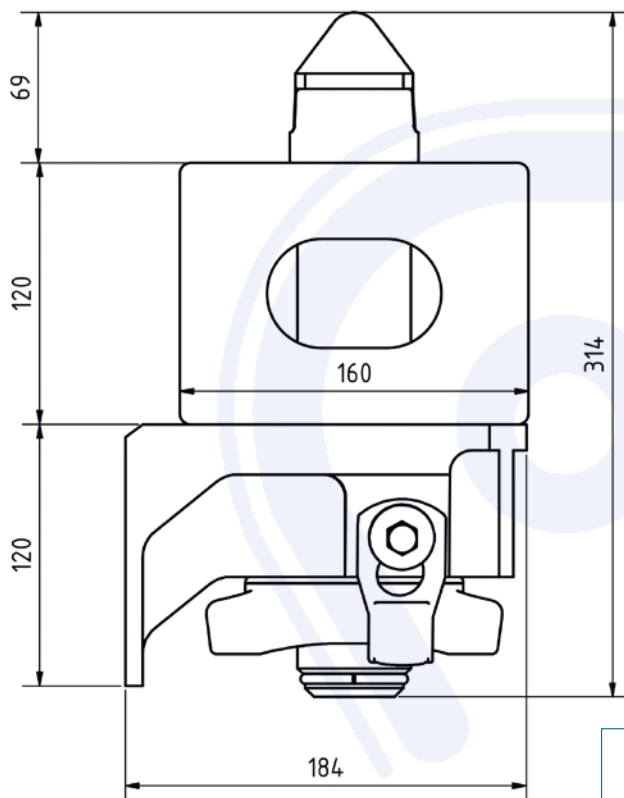

Pos.	Spare part	Art.-No.
1	Intermediate layer 120 mm	905.167.202
2	Housing kpl.	905.300.216
3	Locking pin	905.000.213
4	Locking nut	905.000.088
5	Security ring	905.000.187
6	Security latch	905.159.005
7	Screw	020.008.016
8	Washer	905.036.005